

# LED BIKE LIGHT SET

GB IE NI  
**LED BIKE LIGHT SET**  
 Operation and Safety Notes

DE AT CH  
**LED-FAHRRADLEUCHTEN-SET**  
 Bedienungs- und Sicherheitshinweise

Model-No. 14133

IAN 285919

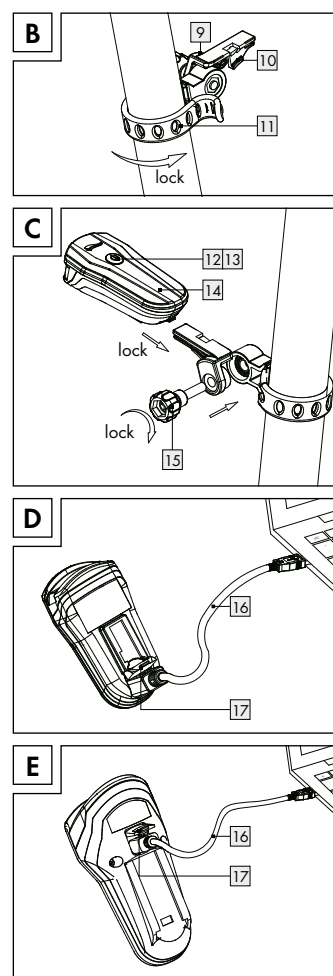
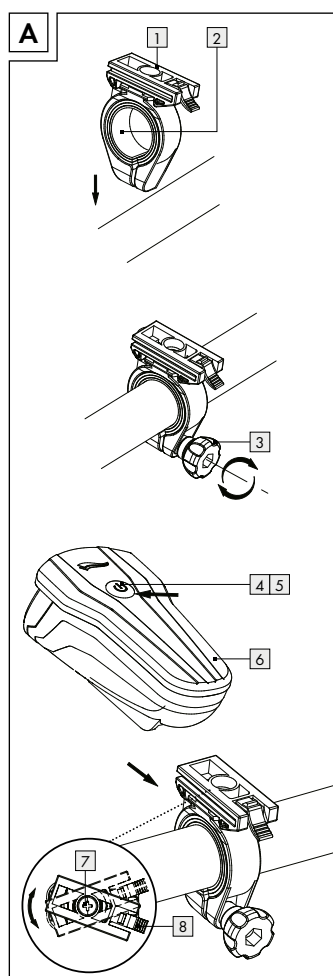

| List of pictograms used |   |
|-------------------------|---|
|                         | Read the instructions!  |
|                         | Danger to life and risk of accident for infants and children!                     |
|                         | Observe the warnings and safety notices!  |
|                         | Caution! Explosion hazard!  |
|                         | Green Dot - Packaging recycling.  |
|                         | Symbol identifying electrical and electronic devices.                             |
|                         | Improper disposal of rechargeable batteries may result in environmental damage!   |
|                         | USB - Universal Serial Bus - Connection port, e.g. on a computer (charging only). |
|                         | Federal Motor Transport Authority test symbol (K followed by approval number).    |
|                         | Product and packaging should be disposed in an environmentally friendly manner.   |
|                         | Recycling code for cardboard disposal.  |
|                         | Product meets the applicable European product-specific directives                 |

## LED Bike light set

### Introduction

Congratulations on the purchase of your new device. In doing so you have chosen a top-quality product. The instructions for use are to be considered as part of this product. It contains important safety, assembly and disposal information. Before using the product, please familiarise yourself with all the safety information and instructions for use. The product must only be used as described and for the specified fields of application. If you pass

the product on to anyone else, please be sure to also include all documentation.

### Intended use

This product is suitable for lighting the roadway whilst cycling. The LED Bicycle Light Set is approved as exclusive lighting for all bicycles. Light distribution must not be impaired by other bicycle parts or luggage. The product is intended for outdoor use. Any use other than the aforementioned or any product modification is prohibited and can result in injuries and product damage. The manufacturer is not liable for damages resulting from improper use. This product is not intended for commercial use.

### Parts description

- 1 Headlight bracket
- 2 Reducer rubber
- 3 Headlight bracket retaining screw
- 4 Headlight on / off switch
- 5 Headlight rechargeable battery control system with integrated automatic mode indicator
- 6 Headlight
- 7 Headlight angle adjustment screw
- 8 Headlight lock
- 9 Tail light bracket
- 10 Tail light lock
- 11 Tail light bracket rubber tab
- 12 Tail light on / off switch
- 13 Tail light rechargeable battery control system
- 14 Tail light
- 15 Tail light retaining screw
- 16 USB cable
- 17 Rechargeable battery charging socket (front and rear lights)

### Scope of delivery

- 1 Headlight
- 1 Tail light
- 1 Headlight bracket
- 1 Tail light bracket
- Reducer rubbers
- 1 USB cable
- 1 Instructions for assembly and use

### Technical data

**Headlight (auto-dimming)**  
 Model designation: L1-2A/XC-195S  
 Rated output: 1W  
 Protection type: IP44 according to DIN EN 60529

Rechargeable  
 Li-ion battery: 1300mAh, 3.7V

### Tail light

Model designation: LR-1/XC-242  
 Rated output: 0.2W  
 Protection type: IP44 according to DIN EN 60529

Rechargeable  
 Li-ion battery: 300mAh, 3.7V

### Safety instructions

#### **WARNING! DANGER TO LIFE AND RISK OF ACCIDENT FOR INFANTS AND CHILDREN!**

- Never leave children unsupervised with the packing material due to the suffocation hazard posed by swallowing parts thereof. Children frequently underestimate the dangers.
- Always keep the product away from children. This product is not a toy!
- This product may be used by children 8 years and up as well as by persons with physical, sensory or mental impairments or lacking experience and knowledge, when supervised or instructed in the safe use of the product and understand the associated risks. Do not allow children to play with the product. Cleaning and user maintenance must not be performed by children without supervision. Please note, damages caused by incorrect handling, non-compliance with the operating instructions or interference with the device by unauthorised individuals are excluded.

- Never take the product apart. Improper repairs may result in considerable danger to the user. Repairs should only be carried out by specialist personnel. The LED lights are not replaceable.

**WARNING! RISK OF LOSS OF LIFE AND ACCIDENT!** Using the incorrect charger may cause the headlight [6] and the tail light [14] to be damaged, overheat or even explode. Doing so will void the warranty.

### Safety instructions for rechargeable batteries

- CAUTION! EXPLOSION HAZARD!** Keep rechargeable batteries away from children, do not throw rechargeable batteries into fire, do not short-circuit and do not take apart.
- Failure to observe this instruction may result in the rechargeable batteries discharging beyond their end voltage. This poses a risk of leaking.
- Avoid contact with the skin, eyes and mucous membranes if fluid has leaked from the rechargeable batteries. In the event of contact with battery acid, thoroughly flush the affected area with clean water and seek immediate medical attention.
- Note:** If the red rechargeable battery control light [5], [13] on the headlight [6] or the tail light [14] lights up, please recharge the rechargeable batteries immediately.
- Please note, once the rechargeable battery control system lights up, the lights no longer comply with the Road Traffic Act.

### Installation

#### Installing the headlight (see Fig. A)

- Unscrew the retaining screw [3] from the bracket [1].
- Position the bracket [1] in the desired location on the handlebar. If necessary, use the reducer rubbers [2] to ensure an optimal fit.
- Reinstall the retaining screw [3].
- Tighten the screw hand tight. To prevent damage, do not use tools for this step.
- To adjust to the optimal angle to the direction of travel, loosen the angle adjustment screw [7] 2-3 turns using a cross-tip screwdriver.
- Adjust to the desired angle and tighten the angle adjustment screw [7].
- Slide the headlight [6] into the bracket [1] until you hear it lock into place.
- To release, press the headlight lock [8] and slide the headlight [6] forward out of the bracket [1].
- ATTENTION!** Routinely verify the headlamp adjustment. The light cone must point straight ahead, in the direction of travel, and must not be adjusted too high so as not to blind oncoming traffic.

#### Installing the tail light (see Fig. B and C)

- Secure the bracket [9] to the seat post or the rear cross-bar using the rubber tab [11]. Be sure there are no objects in front of the tail light [14].
- Tighten and hook in the rubber tab [11].
- Loosen the retaining screw [15] on the bracket [9] and adjust to the desired angle.
- Then tighten the screw. Tighten the screw hand tight. To prevent damage, do not use tools for this step.
- Slide the tail light [14] into the bracket [9] until you hear it lock into place.
- To remove the tail light [14] press the tail light locking mechanism [10] and take off the tail light [14].
- ATTENTION!** The tail lamp must be installed and adjusted so the reference axis is parallel to the median longitudinal plane of the vehicle and parallel to the road.

### Operation

#### Switching on / off

The headlight [6] has three brightnesses.

| On / Off switch   |   |
|-------------------|---|
| press once        | Automatic mode: The light intensity adapts automatically to ambient lighting conditions. When automatic mode is switched on [5] the switch flashes green. |
| press twice       | Power mode (50 Lux) for riding in unlit areas   |
| press three times | Standard mode (25 Lux) for riding in lit areas  |
| press four times  | Eco mode (10 Lux) for riding in well lit areas  |
| press five times  | off   |

#### Charging the headlight / tail light (see Fig. D+E)

- Remove the rubber cover from the battery charging socket [17] and connect the USB cable [16] to the battery charging socket [17].
- Then connect the USB plug of the USB cable [16] to a computer / laptop / standard USB charger with 5V DC and 500-1000mA. Using chargers with different specifications can damage the rechargeable battery, thus the headlight. Doing so will void the warranty.
- The headlight [6] and tail light [14] feature a battery indicator. If the indicator lights up red, the rechargeable batteries are drained. The indicator will light up green whilst charging. When the rechargeable batteries are ready to be used again, the indicator will go out and you can use the headlight [6] and tail light [14].
- For the built-in rechargeable battery to operate at full power, please do not charge the headlight rechargeable battery for less than 6 hours the first time (tail light: no less than 5 hours). Please do not stop charging sooner, even if the LED is already extinguished. After this, a charging time of approx. 3.5 hours is recommended for the

headlight (recommended charging time for the tail light is 2.5 hours).

### Cleaning and care

- Never fully immerse the lights. Do not use corrosive or abrasive cleaning agents. Doing so will damage the lights.
- Clean the LED bicycle light set with a slightly damp, lint-free cloth.

### Disposal

The packaging is made of environmentally friendly materials, which may be disposed of through your local recycling facilities.

Contact your local refuse disposal authority for more details on how to dispose of your worn-out product.

To help protect the environment, please dispose of the product properly, not without household waste, when it has reached the end of its useful life. Please contact your local authority for information on collection points and their opening hours.

Defective or old rechargeable batteries must be recycled in accordance with Directive 2006/66/EC and its amendments. Return rechargeable batteries and / or the device to the recycling facilities provided.

### Improper disposal of rechargeable batteries may result in environmental damage!

Rechargeable batteries may not be disposed with household waste. They may contain toxic heavy metals and are subject to hazardous waste regulations. The chemical symbols of the heavy metals are: Cd = cadmium, Hg = mercury, Pb = lead. For this reason, dispose of used rechargeable batteries at a local collection point.

Improper rechargeable battery disposal destroys valuable resources and the hazardous substances in the rechargeable batteries may pose a significant danger to human health and environment. Separate collection / disposal of old rechargeable batteries prevents dangers to human health and environment, and valuable resources regained by recycling.

### Warranty

Dear customer, This device is covered by a 3-year warranty from the date of purchase. In the event of product defects, you have legal rights against the retailer of this product. Your statutory rights are not limited in any way by our warranty detailed below.

#### Warranty terms

The warranty period begins on the date of purchase. Please retain the original receipt safely. This documentation is required as the proof of purchase. Should a defect in material or manufacture occur within three years from the date of purchase of this product, we will repair or replace - at our choice - it free of charge. This warranty is conditional on the defective device and the receipt of purchase being presented within the three year warranty period, and that there is a brief written description of the nature of the defect and of the date it arose. If the defect is covered by our warranty, you will receive the repaired product or a replacement. A repair or exchange of the device does not extend a new warranty period. The warranty period will not be extended by repairs made under warranty. This also applies to replaced and repaired parts. Any damage or defects present at the time of purchase must be reported immediately after unpacking. Repairs made after the expiration of the warranty period are subject to payment.

#### Extent of warranty

The device was manufactured to strict quality guidelines and diligently inspected prior to shipment. The warranty applies to defects in material or manufacture. This warranty does not apply to product parts subject to regular wear and therefore considered wear parts

Please follow the instructions below to ensure your claim is processed quickly:

- Please have your receipt and the product number ready as your proof of purchase.
- Please refer to the type plate or the cover sheet of these instructions for the product number.
- In the event of malfunctions or other defects, please first contact the following service department by phone or e-mail.
- A product determined defective may then be returned to the specified service address free of charge, including the proof of purchase (receipt) and information about the defect and when it occurred. Please note, the service department must be notified before returning the product!

This and many other manuals, product videos and software are available for download at [www.lidl-service.com](http://www.lidl-service.com).

**GB**  
 KLB GmbH  
 Diekbree 8  
 DE-48157 Münster, GERMANY  
 Phone: +49 2 51 132 37 57  
 email: [gb@klb-service.eu](mailto:gb@klb-service.eu)  
[www.klb-service.eu](http://www.klb-service.eu)

